

4

3

2

1

NOTES, UNLESS OTHERWISE SPECIFIED

- 1. UNSPECIFIED FILLET RADII .005-.010.
- 2. MATERIAL: AL BAR 6061-T651
- 3. THREADS PER ANSI B1.1.

REV	ZONE	DESCRIPTION	APPROVED	DATE
-		INITIAL RELEASE		

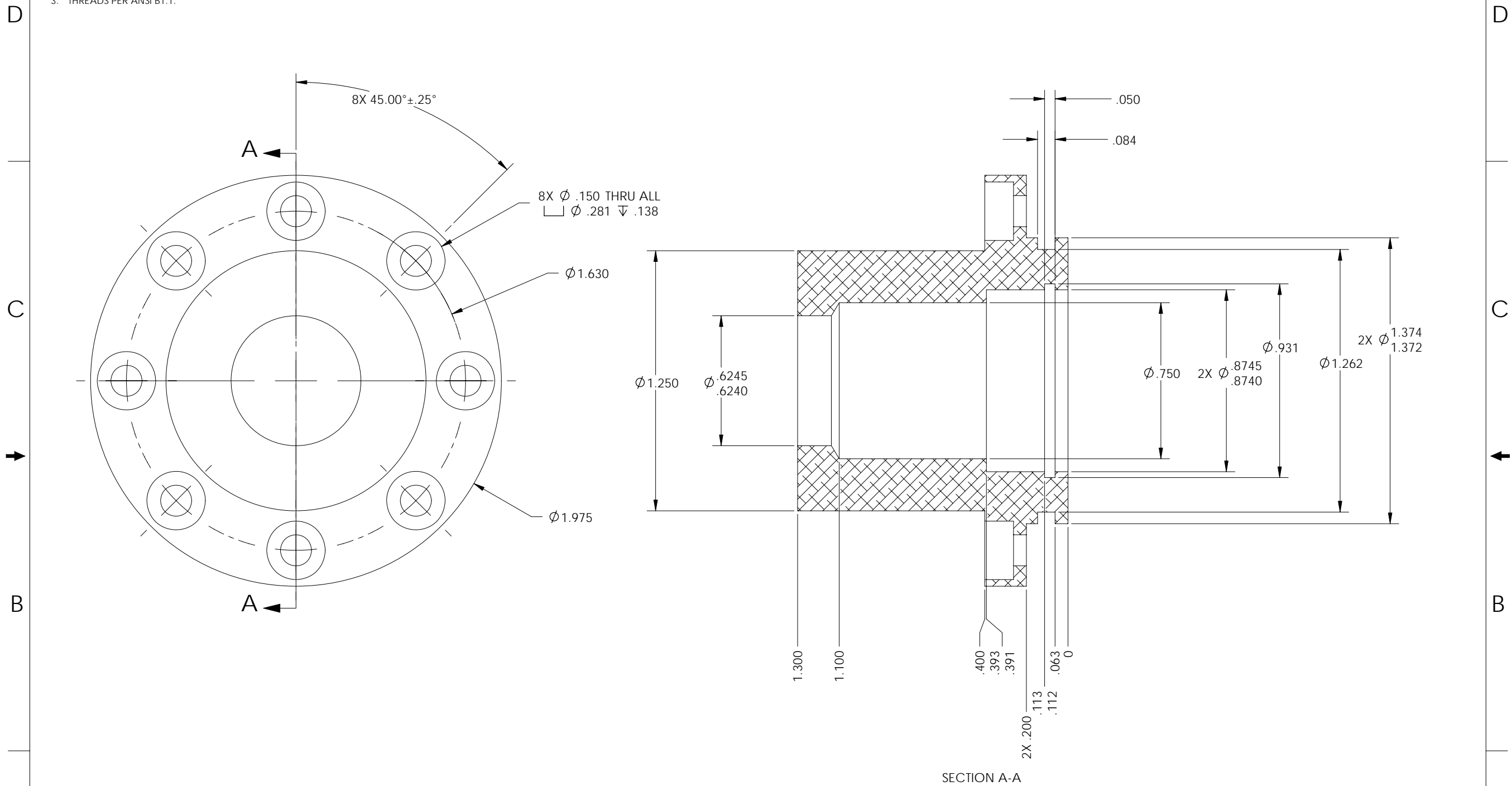

ALL DIMENSIONS ARE IN INCHES- INTERPRET DRAWING PER ASME Y14.5 -1994

TOLERANCES UNLESS OTHERWISE SPECIFIED:

X.X ± .03 $\angle \pm .5^\circ$
 X.XX ± .01
 X.XXX ± .005 125°

REMOVE ALL BURRS AND SHARP EDGES .005 R OR CHAMFER MAX

APPROVED	DATE
PREP BY D. ANDERSON	3-28-08
CHECKED	
RESP ENG	
MFG ENG	
QUAL ENG	

Franklin W. Olin College of Engineering

HOUSING, BEARING

SIZE C	FSCM NO.	PART NO.	PART REV	DOC REV 01
SCALE 3:1	WT	SHEET 1	OF 1	

4

3

2

1

A A B B C C D D